

Threaded Flanges - EN1092-1

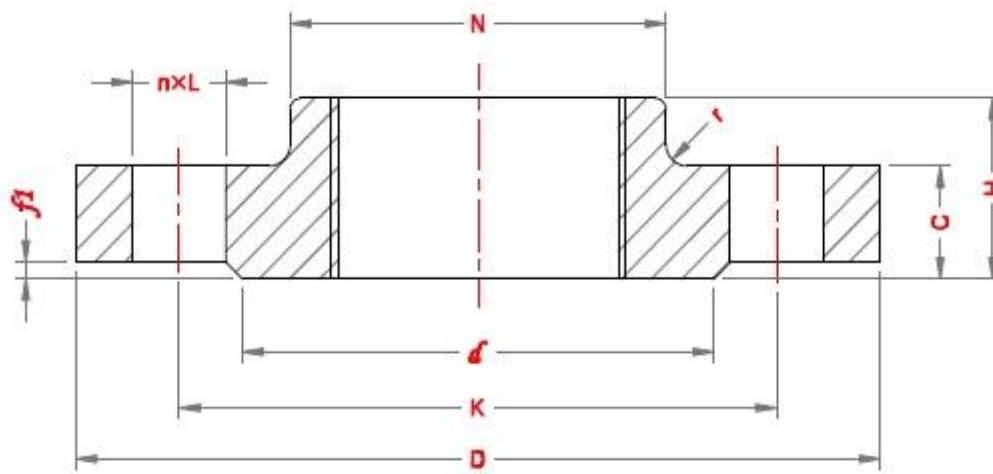

PN 16

DN	Pipe OD, A	Outside Diamete, D	Diameter of Bolt Circle, K	Dia of Bolt Hole, L	No. of bolt	Diameter of Raised Face, d	Height of Raised Face, f1	Flange thickness, C	Length of Flange, H	Neck Diameter, N	Radius of Corners, r
10	17.2	90	60	14	4	40	2	16	22	30	4
15	21.3	95	65	14	4	45	2	16	22	35	4
20	26.9	105	75	14	4	58	2	18	26	45	4
25	33.7	115	85	14	4	68	2	18	28	52	4
32	42.4	140	100	18	4	78	2	18	30	60	6
40	48.3	150	110	18	4	88	3	18	32	70	6
50	60.3	165	125	18	4	102	3	18	28	84	6
65	76.1	185	145	18	8	122	3	18	32	104	6
80	88.9	200	160	18	8	138	3	20	34	118	6
100	114.3	220	180	18	8	158	3	20	40	140	8
125	139.7	250	210	18	8	188	3	22	44	168	8
150	168.3	285	240	22	8	212	3	22	44	195	10
200	219.1	340	293	22	12	268	3	24	44	246	10
250	273	405	355	26	12	320	3	26	46	398	12
300	323.9	460	410	26	12	378	4	28	46	350	12
350	355.6	520	470	26	16	438	4	30	67	400	12
400	406.4	580	525	30	16	490	4	32	63	456	12
450	457	640	585	30	20	550	4	34	68	502	12
500	508	715	650	33	20	610	4		73	557	12
600	610	840	770	36	20	723	5		83	658	12