

Weld Neck Flanges - EN 1092-1

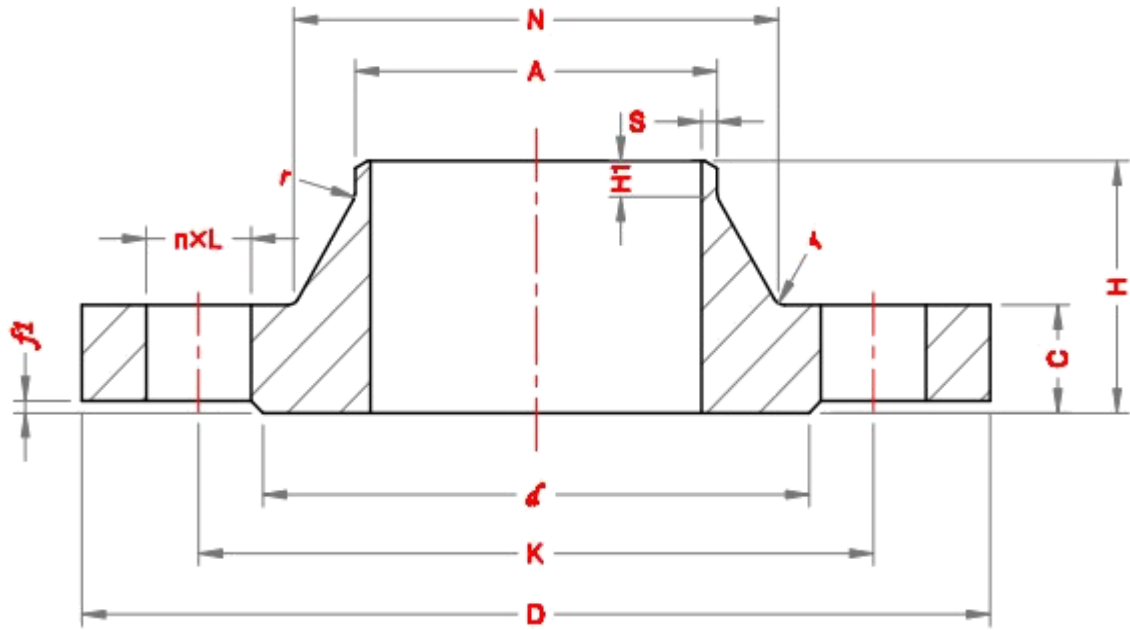

PN 320

DN	Pipe OD, A	Outside Diameter, D	Diameter of Bolt Circle, K	Diameter of Bolt Holes, L	No. of bolts	Diameter of Raised Face, d	Height of Raised Face, f1	Flange thick, C	Length of Flange, H	Neck Diameter, N	Wall thick, S	Length of right end, H1	Radius of Corners, r
10	17.2	125	85	18	4	40	2	24	58	44	2.6	6	4
15	21.3	130	90	18	4	45	2	26	60	48	3.2	6	4
20	26.9	145	100	22	4	58	2	30	70	58	4.0	8	4
25	33.7	160	115	22	4	68	2	34	78	68	5.0	8	4
32	42.4	175	130	26	4	78	2	36	83	80	5.6	8	4
40	48.3	195	145	26	4	88	3	38	88	92	6.3	10	6
50	60.3	210	160	26	8	102	3	42	100	106	8.0	10	6
65	88.9	255	200	30	8	122	3	51	120	138	11.0	12	6
80	101.6	275	220	30	8	138	3	55	130	156	12.5	14	8
100	133	335	265	36	8	162	3	65	145	186	16.0	16	8
125	168.3	380	310	36	12	188	3	75	175	230	20.0	20	8
150	193.7	425	350	39	12	218	3	84	195	265	25.0	25	10
200	244.5	525	440	42	16	285	3	103	235	345	30.0	30	10
250	323.9	640	540	52	16	345	3	125	300	428	40.0	40	12