



HEBEI HAIHAO GROUP
Mengcun, Cangzhou, Hebei, China
www.haihaopiping.com

ISO, ABS, CE/PED APPROVED
Professional Steel Piping Solution
Email: sales@haihaogroup.com

DIN 86029

Hubbed slip-on flanges for welding: nominal pressure 10

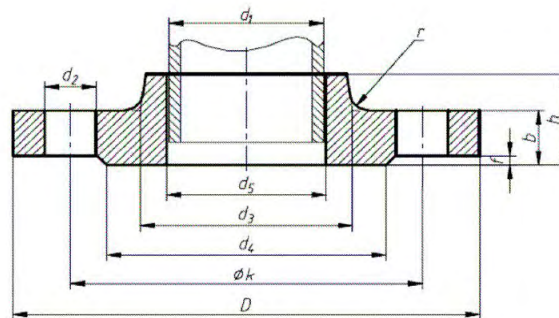

measurements in mm

Nominal size DN	pipe OD d ₁	flange					neck		gasket width d ₄	face height f	screws			weight (7.85 kg/dm ³) kg
		D	d ₅	b	k	h	d ₃	r			number	thread	d ₂	
For nominal sizes DN 10-175 use DIN 86030 Nominal pressure 16														
200	219,1	340	222	24	295	44	247	6	268	3	8	M 20	22	9,9
250	273	395	276	26	350	46	300	6	320	3	12	M 20	22	12,7
300	323,9	445	327	26	400	46	352	6	370	4	12	M 20	22	14,4
350	355,6	505	359	26	460	53	398	10	430	4	16	M20	22	22,3
400	406,4	565	410	26	515	57	448	10	482	4	16	M24	26	26,7
(450)	457	615	461	28	565	62	502	10	532	4	20	M24	26	32,3
500	508	670	512	28	620	67	552	10	585	4	20	M24	26	37,3
600	610	780	614	28	725	75	658	10	685	5	20	M27	30	48,3
700	711	895	716	30	840	77	760	10	800	5	24	M27	30	62,7
800	813	1015	818	32	950	84	864	10	905	5	24	M30	33	83,4
900	914	1115	920	34	1050	88	969	10	1005	5	28	M30	33	99,2
1000	1016	1230	1022	34	1160	92	1071	10	1110	5	28	M33	36	116,8

Do not use Nominal sizes in parentheses wherever possible.

Tolerances table 2

Nominal size DN	D	d ₅	b	k	h	d ₄	d ₂	d ₃	r	f
200 and 250	± 1	+1	± 1,5	± 1,6	± 2	0	+ 0,50	DIN 7168-g		
300	± 3				0	± 3	- 2			
350		± 5	+ 1,5	± 1,6	± 3	0	+ 1			
400	0					0				
450 and 500	± 5	+ 1,5	± 1,5	± 1,6	± 3	0	0			
600										
700 to 1000	± 3 / 0	± 1,5	± 1,5	± 1,6	± 3	0	0			